

Trimmer E

3-axis corner cleaning machine

Top CNC controlled multitool unit 01

Automatic frame centring 02

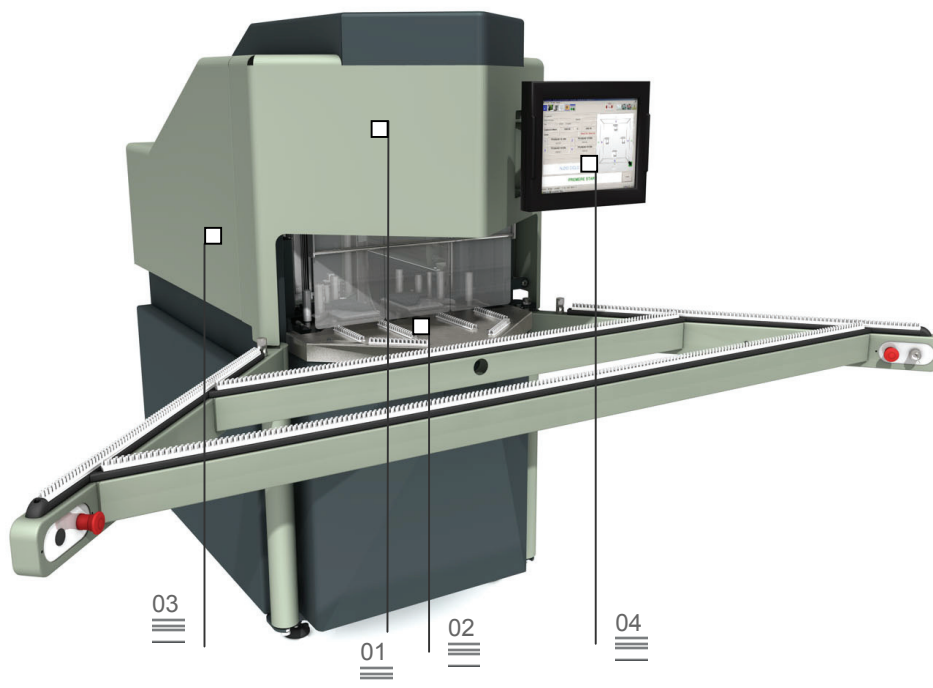

TRIMMER E is a CN controlled corner cleaning machine for PVC frames, with 3 interpolating axes and automatic cycle. It has a 300 mm diameter blade which allows, with different work programmes, cleaning the outer corner on various profiles. It also has top and bottom units with knife for cleaning the welding beads plus top and bottom units with knives for cleaning the inner corners. Machining of the inner and outer corners can be completed with the top and bottom drilling/milling units for cleaning the corners or gasket grooves. The machining units can be programmed independently from each other via a CNC PC which controls programming of the profiles and machine operation. When the machine is suitably configured with the necessary tools, it can handle all types of standard profiles including acrylic and coated profiles. A third CN controlled axis manages the movement of the group of top units, which can hold up to 4 tool units.

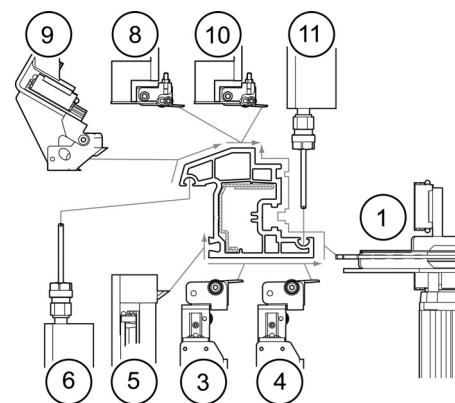

Cleaning module with 2 interpolated axes 03

Orientable interface 04

Profile size control 05

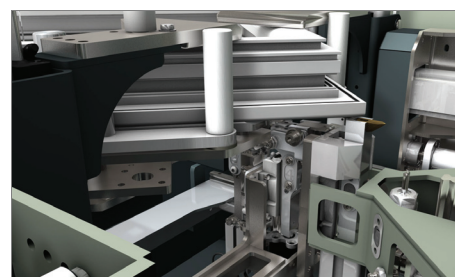

The pictures are provided by way of illustration only

Trimmer E

3-axis corner cleaning machine with CNC PC

01

Top CNC controlled multitool unit

Machining with the top unit is carried out with tools mounted on a 4-position rotating group. A CNC controlled axis automatically brings the tool that will be used to the operating position. The group mounts two linear knives to clean the white and film-coated profiles, a double universal tool to clean inclined and rounded corners, a milling unit to clean gasket grooves.

02

Automatic frame centring

A self-centring mobile work table makes it easy to insert the frame into the machine, by automatically positioning the welding bead of the corner in line with the tools. The knives guided by bearings that copy the surface of the profile and the high precision of the interpolated axes that guide the disc milling tool, allow for perfect cleaning of white and film-coated profile.

03

Cleaning module with 2 interpolated axes

The movement of the tools unit is managed by two high precision and quick-positioning interpolated axes, to ensure high quality standards in the same amount of time as superior category automatic machines. All movements are performed on linear recirculating ball slideways, ensuring the required rigidity and precision.

04

Orientable interface

Special care has been taken over the ergonomic aspects of the machine: the particular look of the machine embodies the objectives regarding protection and accessibility. The interface is easily orientable, allowing the operator to set and programme the machine from either the loading position or the right side, where the sliding lateral guard allows the work cycle in progress to be viewed.

05

Profile size control

As the profile is being positioned in the machine the position of the clamping hold-downs is verified. This measurement information allows the CNC to compare it with the main size parameters of the profile (thickness and height). The insertion of a profile different than expected by the programme will block processing and generate an error message, requesting the correct profile to be inserted and reducing human error to a minimum.

MACHINE CHARACTERISTICS

Y axis speed (m/min)	22,5
Z axis speed (m/min)	11,25
W axis speed (rad/s)	5
Y axis acceleration (m/s ²)	2,5
Z axis acceleration (m/s ²)	2,5
W axis acceleration (rad/s ²)	10
Milling different profiles	optional
Maximum size of manually fed frames	unlimited
Minimum size of the frame, outer measurement (mm)	290 x 290
Minimum size of the frame, inner measurement (mm)	160 x 160
Maximum height of the profile (mm)	180
Minimum height of the profile (mm)	35
Maximum width of the profile (mm)	150
Diameter of blade shaft (mm)	32
Diameter of blade (mm)	300
Blade speed (rpm)	2.800
Consumption (kw)	3,5
Overall dimensions (width x length x height) (mm)	920 (2460) x 2179 x 1782
Air consumption (NI/min)	120
Weight (kg)	620